



6 Materials Batching Controller

Model FC703

Specification

- 1、 High display resolution, display resolution 1 / 50000
- 2、 Up to six kinds of materials
- 3、 Fault detection capabilities to help customers quickly find the point of failure
- 4、 Parameter backup function

Dimension

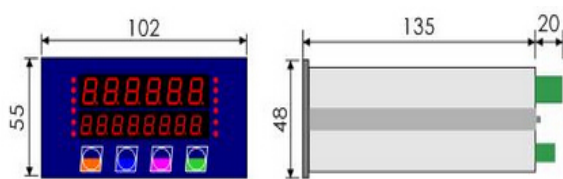

Front Panel

Side View

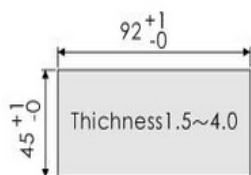

For Mounting

DIN
96×48



Applications

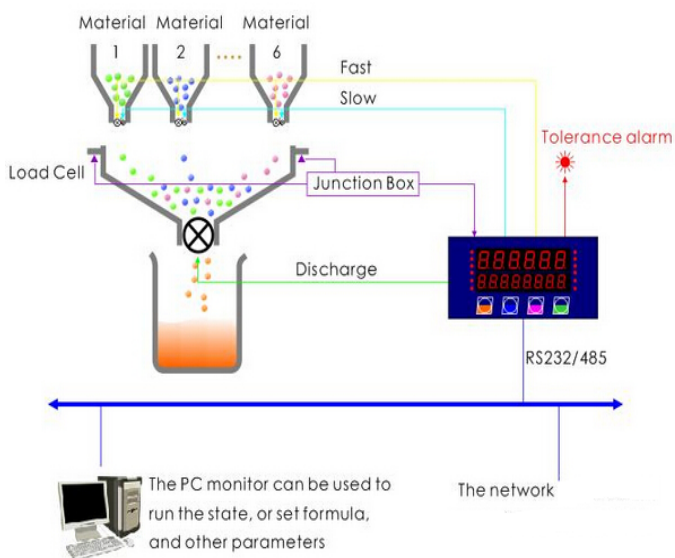

Power supply	DC18~36V ,About 8W(standard) AC85~265V(50/60Hz), About 8W(option)
Weighing process	AD sampling method:Delta-Sigma method AD sampling speed:100 times/second Internal resolution:1/260000 Display resolution:1/50000(MAX) Non-linearity:0.005%F.S.
Weighing Interface	Input Sensitivity:≥0.125uV/d Input signal range:– 30.5~30.5mV Zero signal range:– 30.5~30.5mV Excitation voltage:10V±1% Drive capability:Up to four 350Ωload cells can be connected
Switch interfaces	Input 2, which one can be customized Output 10, which one can be customized
Options	Communication board: RS232 or RS485 optional
Communication protocol	MODBUS RTU protocol, Custom protocol
Others	Installation method: Panel mounting Protection class: IP65 Weight: about 0.65kg Working environment Temperature: -10~45°C Humidity: 10~90%R.H Display: 6 high-brightness red LED (13mm) Indicator: 12 Key: 4 On display: 6 high-brightness red LED (7mm) The following shows: 8-bit high-brightness red LED (6mm)